

Single lever 'large' washbasin mixer TENDER_C2000490



MODEL **C2000490**

Single lever 'large' washbasin mixer, with automatic 1"1/4 automatic pop-up waste, G.3/8" stainless steel flexible hoses

AVAILABLE FINISHINGS



CHARACTERISTICS

Cartridge Spare Parts **ZZ95435000**

35 mm Cartridge

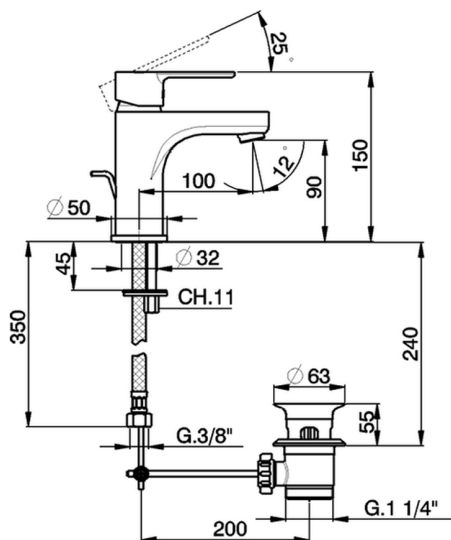

EcoStop

EcoStop feature limits water flow to approximately 50% of maximum output with one point of resistance on setting. Push slightly past the middle stop only when full water output is required. This will save water up to 50%.



Single lever 'large' washbasin mixer TENDER_C2000490

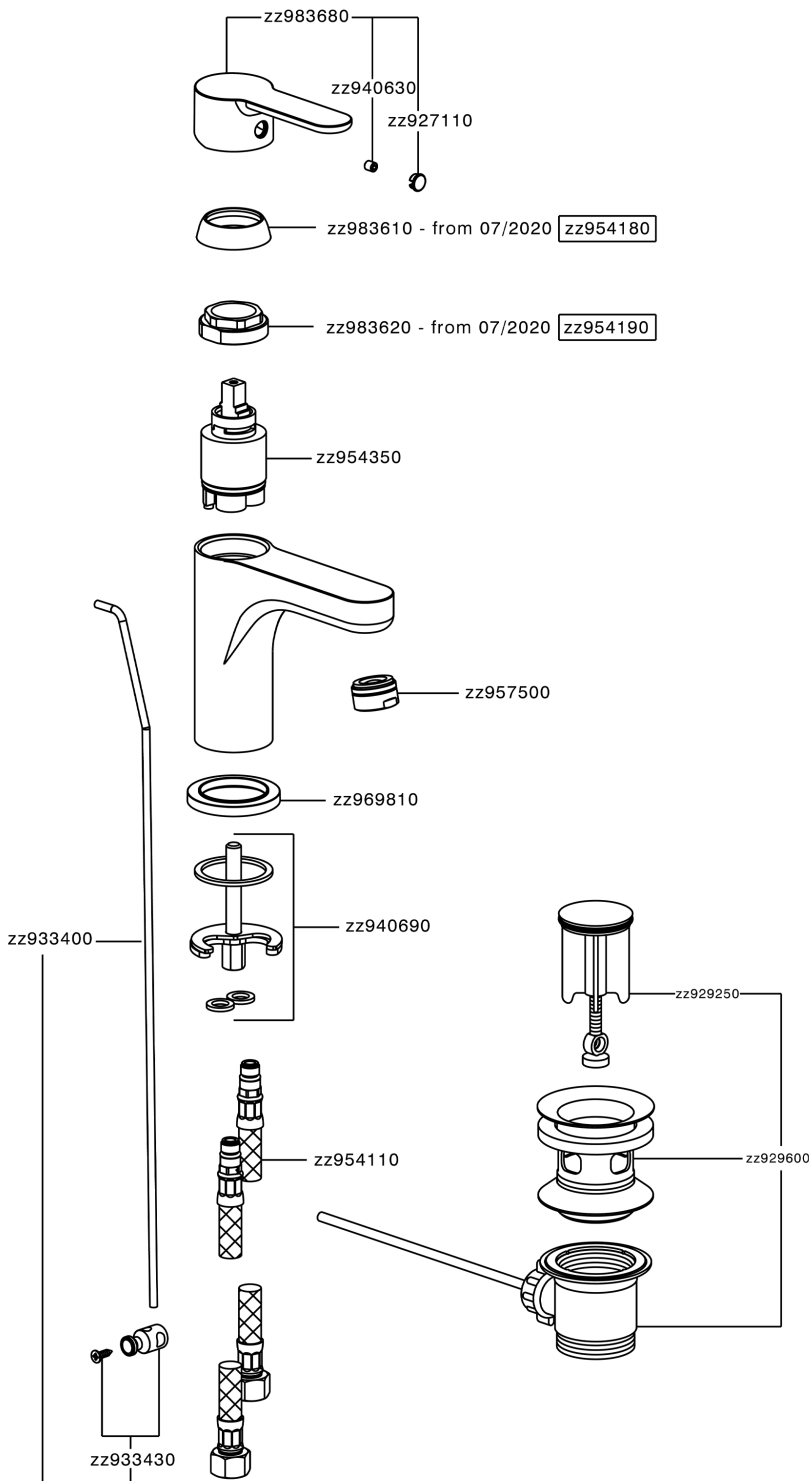

C2000490

<https://en.cisal.it/single-lever-large-washbasin-mixer-tender-c2000490>

2024-12-22